



# Building Guide

Colorado Chapter of the International Code Council

## Single Family Residential One Story Detached Garage

### How to Use this Guide

Check with your jurisdiction regarding type of submittal (paper or electronic) and for any additional requirements. Draw to scale or provide dimensions and complete the following (hint: use graph paper with 1/4" squares. Example: 1/4" = 1").

- 1. Complete this Building Guide** by filling in the blanks on page three and four and indicate which construction details will be used on page five.
- 2. Provide a Plot Plan(site plan)** showing the dimensions of the proposed garage, its relationship to existing buildings/ structures, the distances to adjacent property lines and the distance to any other structures existing on the lot.
- 3. Fill out Building Permit Application**

The majority of permit applications are processed with little delay. The submitted documents will help determine if the project is in compliance with building safety codes, zoning ordinances and other applicable laws.

The Colorado Chapter of The International Code council is a professional organization seeking to promote the public health, safety, and welfare of building construction. We appreciate your feedback and suggestions. Please write to Colorado Chapter of the International Code Council, at P.O. Box 961, Arvada, CO 80001. This Building guide can be found on the Colorado Chapter of the International Code Council website at:  
<http://www.coloradochaptericc.org>

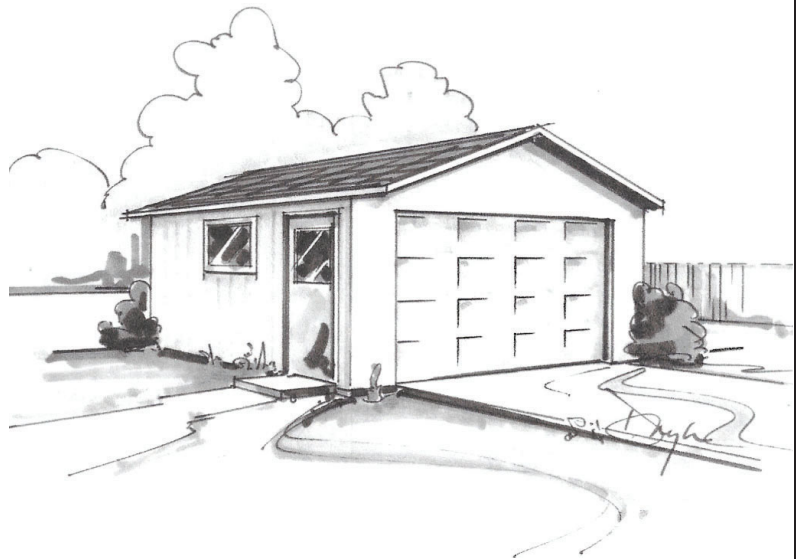

This handout was developed by the Colorado Chapter of The International Code council as a basic plan submittal under the 2021 International Residential Code. It is not intended to cover all circumstances. Check with your local authority having jurisdiction (AHJ) for any additional requirements.



# Single Family Residential One Story Detached Garage

Address: \_\_\_\_\_

**Note:** Provide a plot plan (site plan) showing the dimensions of the proposed garage, its relationship to existing buildings/ structures, the distances to adjacent property lines and the distance to any other structures existing on the lot. Include a compass or north facing arrow.

## Site Plan Example

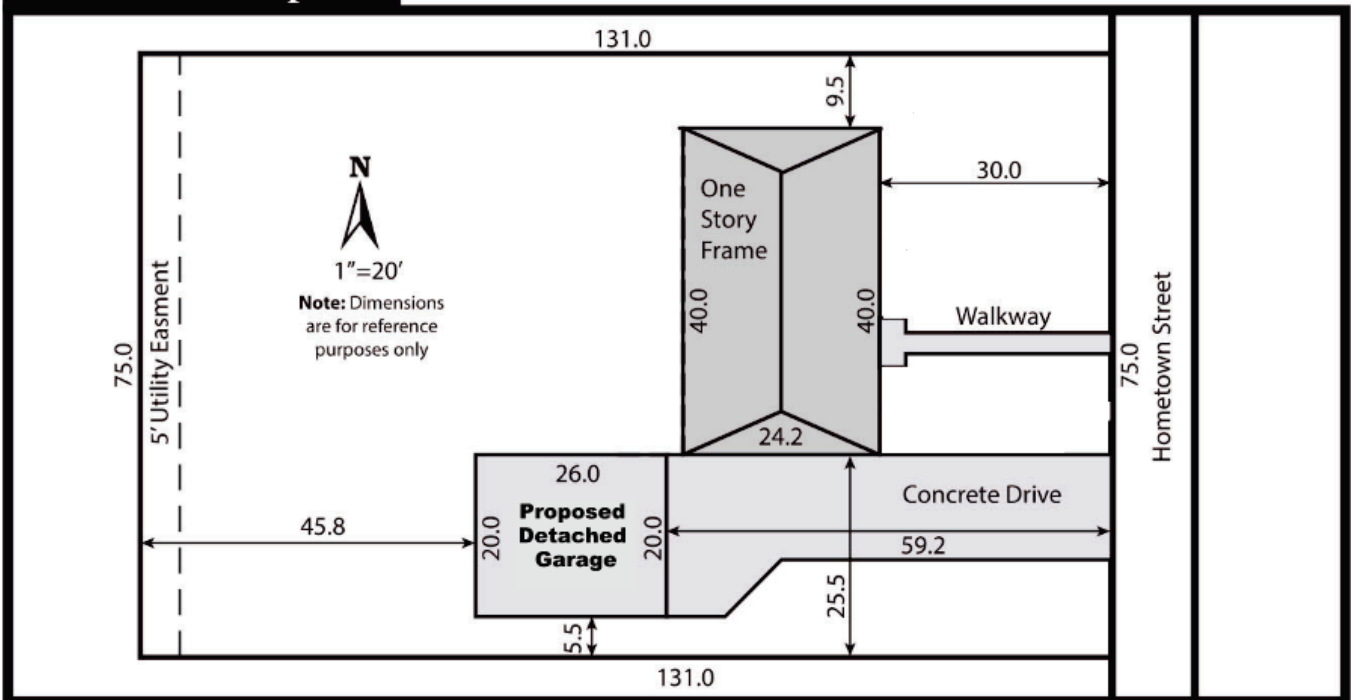

This handout was developed by the Colorado Chapter of The International Code Council as a basic plan submittal under the 2021 International Residential Code. It is not intended to cover all circumstances. Check with your local authority having jurisdiction (AHJ) for any additional requirements.



# Single Family Residential One Story Detached Garage

## Directions:

1. Fill in the blanks on pages three and four. Please print legibly.
2. Indicate which detail on page five will be used for your project.

**Note:** Conditioned garages may be required to meet energy code requirements such as insulation requirements in the ceilings, exterior walls, and around the foundation. Check with your local AHJ for specific requirements.

## Floor Plan

Dimension

Locate and detail bracing

Check one

Garage is heated  
 Garage is not heated

Show door and window header sizes and location and size of landing in front of door

3 1/2" minimum concrete slab

( ) X header  
*(example: (2) 2 x 12)*

**Note:**  
If roof trusses or rafters bear on header, special header design may be required

Double 2x4 or 2x6 trimmers each end of overhead door header

Garage door opening

Garage door opening width

Dimension\*

Dimension\*

Floor slope

Check one  
Indicate rafter or truss direction

\* If less than 4' see Braced Wall Panel Detail on page 5 to comply with section R602.10.6.2 (IRC) (minimum width 16" with wall 10' high)

This handout was developed by the Colorado Chapter of The International Code Council as a basic plan submittal under the 2021 International Residential Code. It is not intended to cover all circumstances. Check with your local authority having jurisdiction (AHJ) for any additional requirements.



# Single Family Residential One Story Detached Garage

**Notes:**

1. For roofs with slopes less than 4:12, follow manufacturer's requirements for low slope application of roofing material.
2. Pre-engineered roof trusses with uplift connectors/ hurricane ties may be used in lieu of roof structure shown. Provide stamped truss calculations and layouts.

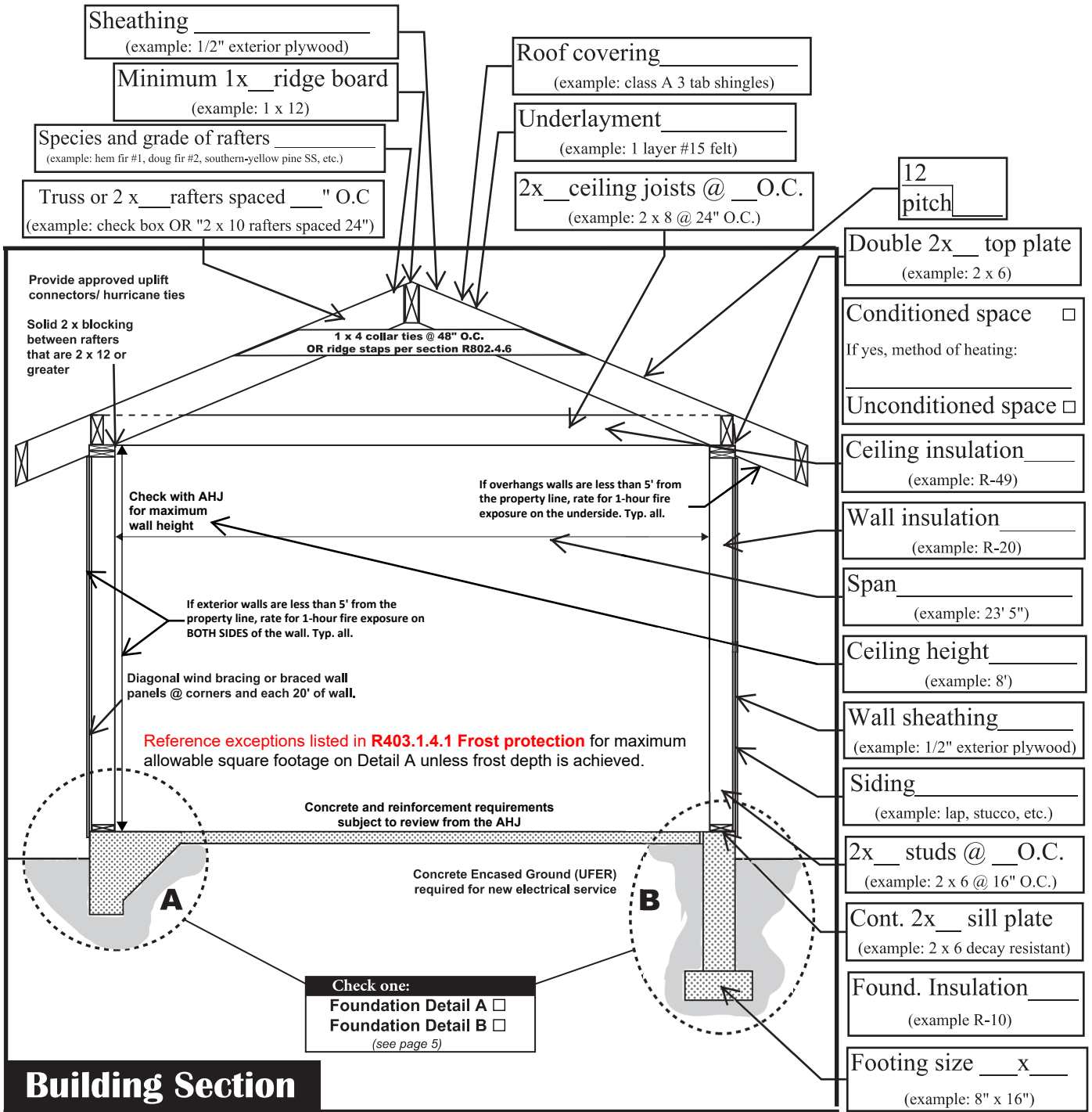

## Building Section

This handout was developed by the Colorado Chapter of The International Code Council as a basic plan submittal under the 2021 International Residential Code. It is not intended to cover all circumstances. Check with your local authority having jurisdiction (AHJ) for any additional requirements.



# Single Family Residential One Story Detached Garage

## Foundation Detail A

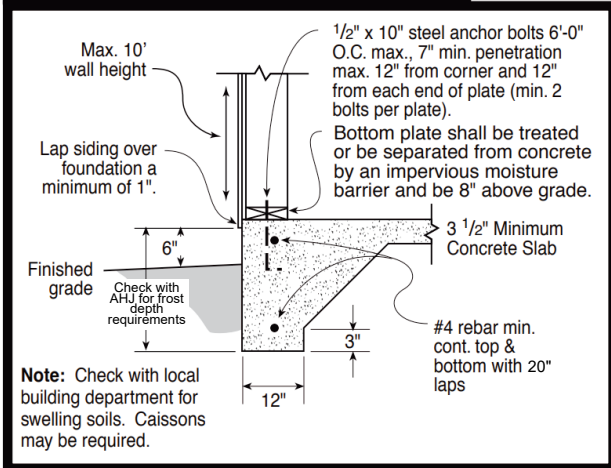

## Foundation Detail B

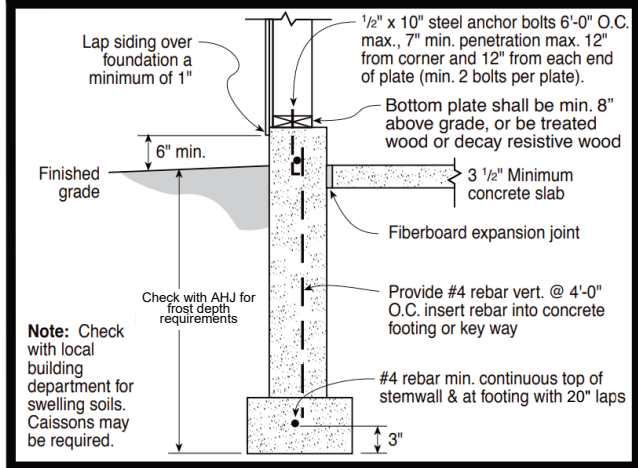

## Braced Wall Panel Detail figure 602.10.6.2

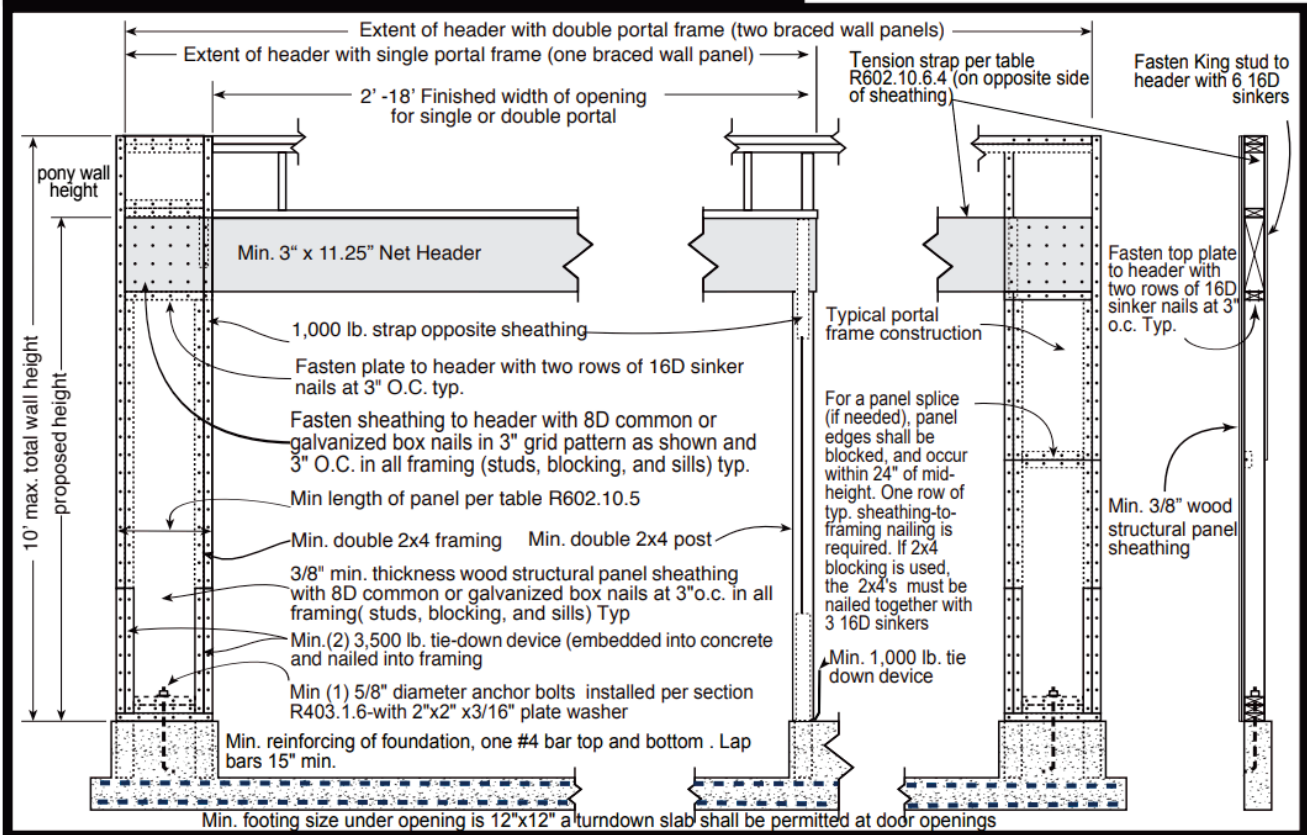

This handout was developed by the Colorado Chapter of The International Code council as a basic plan submittal under the 2021 International Residential Code. It is not intended to cover all circumstances. Check with your local authority having jurisdiction (AHJ) for any additional requirements.

